

M3

Pressure balance mixing valve

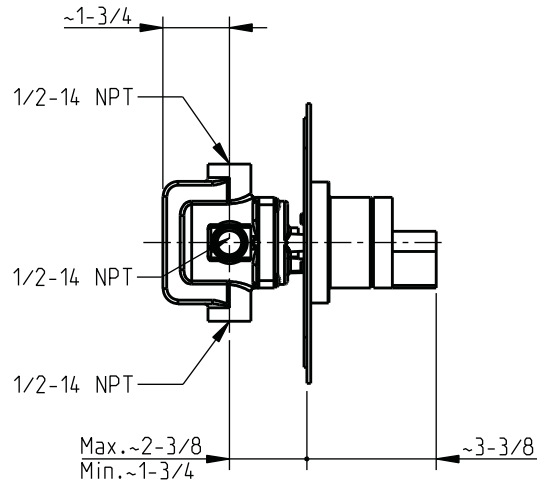

dimensions inches

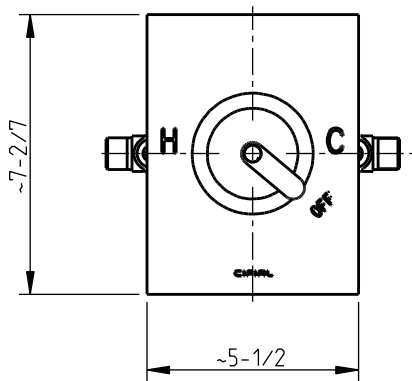
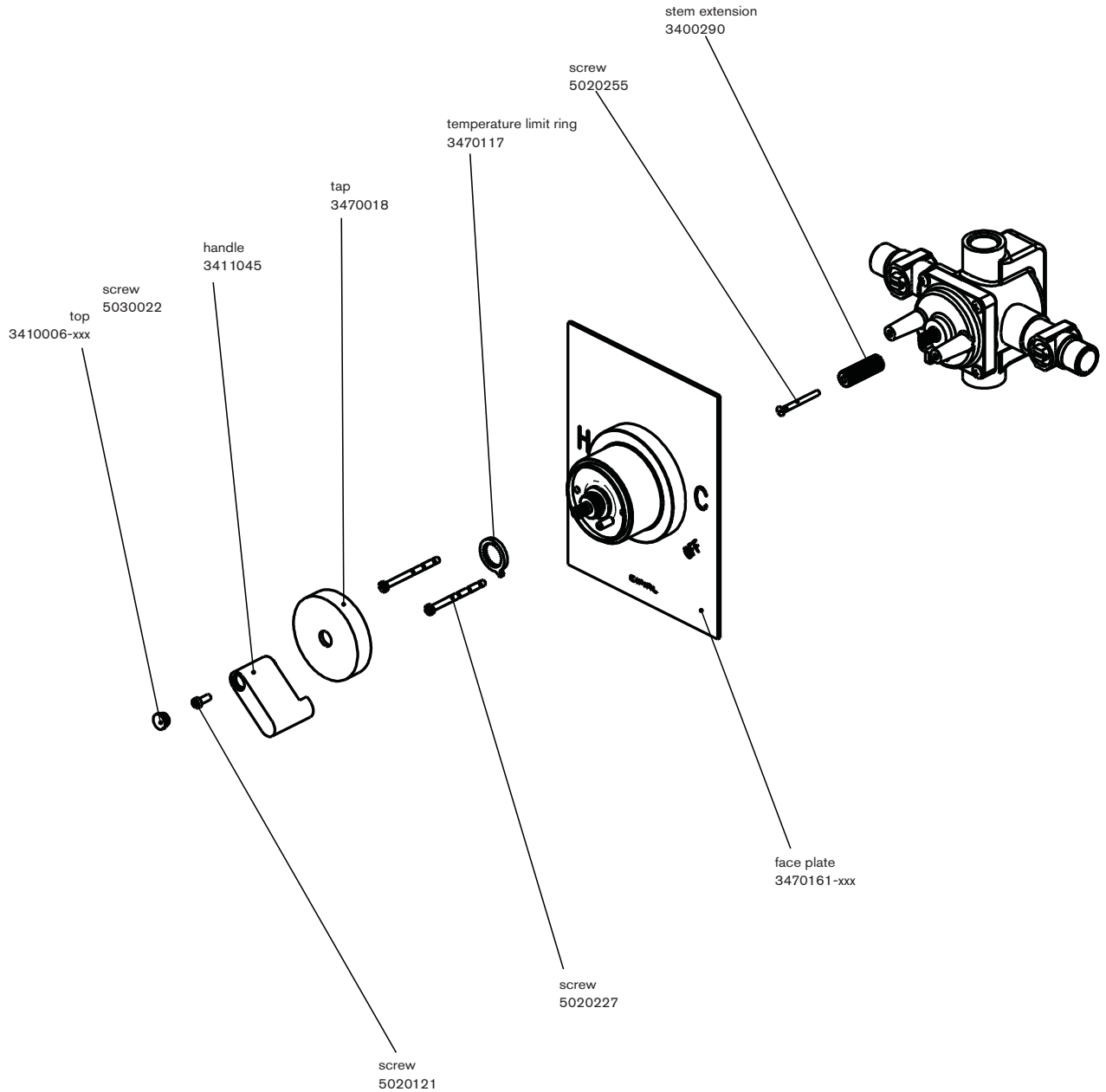

assembly instructions

1. Pressure balance rough valve is sold separately.
2. Place stem extension onto valve stem.
3. Insert upper link/diverter extension into body valve diverter spindle.
4. Thread diverter sleeve into rough valve.
5. Slide face plate assembly into place and engage stem extension into handle drive shaft using face plate screws.
6. Set high temperature limit stop by turning handle drive shaft counter clockwise until desired maximum temperature (110°F) is reached. Place limit stop onto handle drive shaft with arm set next to limit stop pin. Turn handle drive shaft clockwise to shut off valve.
7. Place handle escutcheon base and handle onto handle drive shaft so that the handle stands in the OFF position (5 o'clock). Tighten with handle screw and insert handle top.
8. Thread diverter pull knob into diverter extension.