

289.717.999

Thermostatic Valve w/o Volume Control.

Flowrate: 18.5 GPM @ 60 PSI

*****Volume controls must be used with this valve!*****

**Inlets marked and color coded hot and cold.
Valve will not operate properly if hot and cold reversed!**

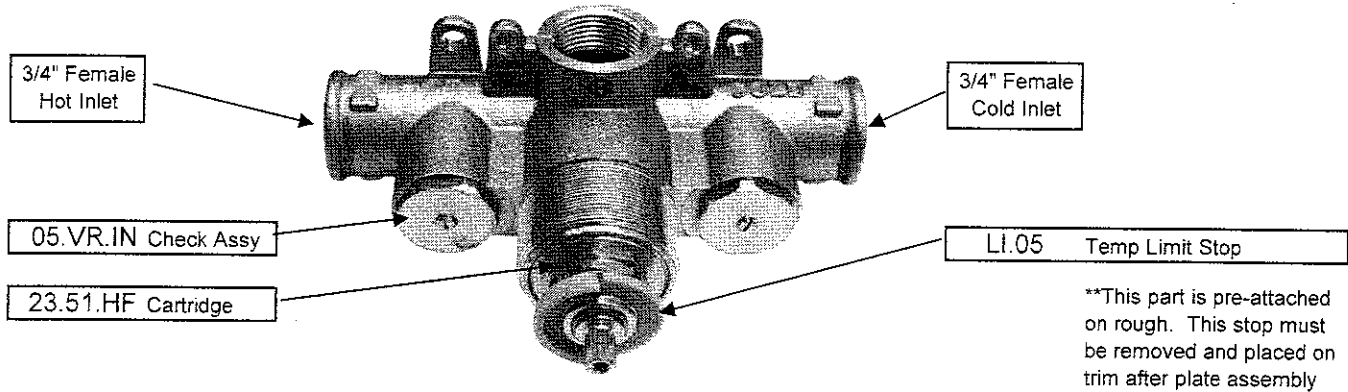

Installation dimensions	Min: 2-5/8"
(Measured from Center of inlets to Finished wall)	Max: 3-7/8"

Calibrating valve temperature.

Valves are calibrated from the factory and should operate at the correct temperature once installed. If you determine that the temperature is not correct or if maintenance is performed on the valve, calibration may be needed in order for proper temperature control. Please follow the the steps below to calibrate the thermostatic valve.

1. Fit white/gray plastic ring onto valve spindle so that the red mark on it points directly up (pictured above). This is the temp override feature that forces the user to use an override button when increasing the water past 100 degrees F.
2. Open the volume control and allow water to run into the shower. Check the temperature of the water from the system with a thermometer. Rotate the valve temp spline slowly until the water is as near 100 degrees as possible. Rotate the spline counterclockwise for hotter water, clockwise for colder water.
3. Once 100 degrees is achieved, you have calibrated the thermostatic valve.
4. Temperature control trim can now be installed.

Maintenance: Use integral stops

To turn the water off at the valve in order to perform maintenance, please use the integral stops on each inlet. These flat slotted screws can be tightened to turn the water off and loosened to turn the water back on. Tighten the screws until they stop in order to turn the water completely off. Once maintenance is complete, please loosen the screws until they stop to insure the stops are completely open. Failure to do so will result in reduced performance.